

INSTRUCTIONS & MAINTENANCE MANUAL

Model “LUNA”

Release: October 2024

USER TIPS

After unpacking, check machine for damage.

When in doubt, do not use the machine and call in qualified professional help.

Do not leave packing components (plastic bags, polystyrene foam, nails, cartons box, etc...) within children's reach, as they are as many potential hazards.

Before plugging machine into mains, check the technical plate (28):

- Correspond to those of the electrical network (27)
- Mains capacity is sufficient for max. nameplate rating.

When in doubt, have professionally qualified people check the system thoroughly.

Improper installation might harm peoples, animals or object and the producer waives any responsibility.

The machine's electric safety is guaranteed only when the machine is properly and effectively earthed as for seen in the current electric safety regulations.

This primary requirement for safety must be checked; in case of doubt, have professionally qualified people check the system thoroughly.

The producer is not liable for any harm or damage caused by a faulty or missing earth connection.

Install a safety switch (4) having 3 mm. breaking gap minimum.

To prevent overheating, unwind power supply cable (7) to its full length.

Do not use adapters, multiple plug and cable extensions!.

The producer is not liable for damage caused by improper or wrong use.

Using any electric appliance calls for complying with some basic rules:

- Do not touch appliance with wet hands or feet.
- Do not use appliances when barefooted.
- Do not pull power cable to unplug the machine.
- Do not expose appliance to weather factors.
- Do not let unsupervised children or unable people use appliance
- Do not set in water or in liquid.

Before cleaning or repairing , cut power off (27) or turn off main switch (8).

Do not leave appliance plugged when not in use.

Turn off the main switch (8) when appliance is not in use.

Follow the instructions for everyday cleaning as given in this manual.

User is not authorized to replace appliance power cable (7).

Power cable (7) can be replacing from qualify personel or from an authorized Officine BRUGNETTI s.r.l.service center

In case of damage or improper functioning switch off the machine. Do not try to repair it yourself, but refer to specialized staff.

Repairs can be performed only by manufacturer or authorized service, using original spare parts only. If these conditions are not observed, the guarantee will be cancelled.

For the proper functioning of the product it's necessary to follow the instructions of the manufacturer strictly and have specialized staff perform periodical maintenance.

Do not expose your hands or other parts of your body in the direction of the coffee, the steamer (17) or hot water (9) outlets. Steam and hot water may cause injuries.

During operation the steam and hot water outlets are very hot; handle them very carefully and only in the places specified for that purpose.

It's allow place cups upon the cup-rest basin (18) after they have well dried. It's incorrect to place any other object.

Any unauthorized handling of any part of the machine renders any guarantee null and void.

If the appliance is not used any longer it's recommended to make it unusable, by unplugging the power supply cable (7) from the main electrical network (27) deleting the water connection (1) to the machine and make harmless the parts which could represent a danger specially for children could use the dismissed appliance for their games.

PREMISES

Please read all advices of the present instruction book carefully, since give important indications regarding safety, installation use and service of the product.

Keep the present manual with care. The producer is not responsible for damages caused to people, things or the product itself if used in a different or discrepant way from what is described in the present manual or if the service and safety prescriptions are not observed.

In some regions or States different connections and structural modifications are foreseen. Nevertheless connections and use ways remain unchanged.

The present manual must be kept for future reference until the machine is dismissed.

In case of loss of the manual or enquiry for further information, please get in touch with the authorized area dealer or directly with the producer.

The present manual reflects the know how of the present moment and cannot be overcome only because in a second moment it has been update on the bases of new experiences.

The producer is given the right to modify the present manual without the must of updating the previous editions, except for special cases

Any improper use or discrepancy in following the content of the present manual will not give right to any term of guarantee or liability be the producer.

This product is to used only for the aim for which has been conceived:

- Making espresso coffee by hot water infusion on roasted and mill coffee.
- Collection of steam and/or hot water

This device can be used by children older than 8 years old and people with reduced physical, sensory or mental capabilities without experience and knowledge, if they are given supervision or instruction to use the product safely and to understand the dangers.

Any improper use is to be considered dangerous.

MAIN COMPONENTS

The coffee machine is composed as follow:

- **BOILER:** It's for containing hot water and steam, made in copper for keeping its qualities unchanged at long time.
- **GROUP:** It's the component , where after filter holder application, coffee infusion and supplying is carried out.
- **FRESH-WATER SYSTEM:** One for each group is draw in the boiler hot-water. It allows to bring fresh water draw from water network at suitable temperature in short time avoiding extreme temperature gap.
- **HEAT SOURCE:** It's supplied by a heating element placed in the boiler and it's for steam/hot water supply.
- **PUMP:** Device used for raising water network pressure up to 9 bar for exploiting coffee.
- **STEAM TAP:** It allows steam withdraw for whipping milk for making cappuccino, hot chocolate and for heating other drinks.
- **HOT WATER TAP:** It allows hot water withdraw for making hot drinks.

CONTROL DEVICES:

- **Manometer :** it shows boiler and /or pump pressure
- **Pressure switch :** it control the pressure in order to unchanged the temperature of the boiler.
- **Electronic box :** It control and is for keeping unchanged water level in the boiler.
- **Display (previous in ST version) :** for programming and informations

INSTALLATION

INSTALLATION WARNING

Although the manufacturer has reasonably for seen every safety to guarantee that user are not hurt it's necessary to evaluate possible remaining risks which can be caused by different installations and placement conditions which can originate uncontrollable and an unforeseeable situation

In consideration of the above we beg to observe our suggestions:

- Packing components can cut, hurt and become dangerous if not handled with care or if used improperly; do not leave within reach of children or unresponsible people.
- Anomalies or defects are to be advise immediately to authorized and qualified service people for service/installation execution.
- It's compulsory that machine must be earthed, and electrical network comply with the current regulations in the country where installation is made.
- The machine installation must be carried out by approved and authorized service people.
- Verify integrity of components and, in case you find defect or anomalies, ask for replacement.
- Verify that the machine voltage correspond to power network supply which is in the installation place.
- User must provide for supplying power to the machine by protecting power line with a suitable safety switch.

CONNECTION TO THE WATER SUPPLY

Before installing coffee machine

BE SURE that:

- Water supply (1) is efficient
- Water supply (1) is drinking water
- Water supply (1) is not subject to pressure changes

MAKE SURE that:

- Water pressure is not lower than 2 bar and not higher than 5 bar (1)

INSTALL a main cock (2) which must be turned off each time coffee machine turn off.
CONTROLL that the main drain (23) is enough to hold the outlet tube (22) of the machine.
DO NOT CONNECT other water pipes between the machine and the main cock (2).

CONNECTION TO THE MAINS

Before installing coffee machine :

BE SURE that:

- Electric network (27) has a earth connection
- Voltage of coffee machine is identical to electrical network
- Power of coffee machine and accessories don't overload main power supply.

INSTALL a safety switch (4)

STARTING UP

- Connect safety switch (4)
- Place the machine on a flat horizontal surface (3° max inclination)
- Allow place for all accessories
- If foreseen, connect water softener to main cock (2). A pressure reducer must be installed if there are pressure changes.
- Connect outlet tube (22) to drain water box (20).
- Connect power supply cable (7) to safety switch (4).
- Turn on the main cock (2)
- Open tap (12) and close (after about 15 min) after steam starting.
- Fill the boilers turning main switch (8) handle on 1/ON position and 2 min.later on 2/ON position.
- About 20 minutes from manometer (14) appear that machine reach the pressure value programmed (1-1,1 bar).
- Hang filter-holder (16) to the group head.
- Machine keeps programmed pressure by pressostat and/or electronic probe.
- Boiler is provided with a safety device which is a spring valve gauged. If pressure goes more than 1,6 bar automatically it unload the over pressure.

MAINTENANCE AND WARNINGS

To ensure perfect safety and efficiency of the machine over time, it's necessary to carry out routine, preventive and special maintenance.

Periodically check the following items (see Tavola 700185):

Daily:

Filters and holder filters must be cleaned in hot water using an envelope or tablet of special detergent.

Cup-rest basin (18) using a sponge

Steam nozzles (17) all times used. Check the holes of the steam nozzles and clean them monthly, clearing out the exit holes with a small needle

Weekly:

Shower plate 8 (C1/65/5) unscrewing the **screw 9**(V093), **holder shower plate 6** (C1/67/2) **containment ring 7** (A059).

Internal parts of the **group head** must be cleaned in the following manner:

- Replace the standard filter of the filter-holder with a solid one
- Pour a teaspoon of a suitable detergent powder on the solid filter and attach the filter-holder (16) to the head group

- Use the delivery switch (11) to set the group in operation.
- Repeat the about operations until the water comes out clean
- Turn off and remove the filter-holder from the group
- Rinse a final time

Annually:

Replace **rubber 10** (600177), **shower plate 8**(C1/65/5)) and 1 and 2 cups **filters** (000033.1/2)

Water softener must be regenerated (if installed) at the programming time.

USE**COFFEE DELIVERY**

Fill the filter with the correct quantity of ground coffee and press it lightly.

The machine is supplied with 2 different filters:

- 7 grams filter for 1 cup
- 14 grams filter for 2 cups

Clean the filter rim with the hand in order to eliminate eventual ground coffee rests.

Fit the filter-holder (16) into the group until it locks.

After lockage we suggest to give an additional hand-hit to the filter-holder (16).

Put one or two cups underneath the delivery spouts of the filter – holder (16).

Push coffee group switch corresponding to the wished dose of key board (11).

The delivery will stop automatically when the wished dose is reached.

HOT DRINK PREPARATION**STEAM DELIVERY**

- Touch handle (12) in anticlockwise direction and in clockwise direction immediately in order to discharge any condensed water which may have collected in the steam tube nozzle (17).
- Introduce steam tube (17) in the liquid to be heated
- Turn on handle (12)
- When liquid has been heated stop steam turning handle (12) in clockwise direction.

HOW TO FOAM MILK TO PREPARE “CAPPUCCINO”

- Purchase a stainless steel milk pitcher of at least ½ lt. capacity.
- Attention : milk spout provide hot steam, please be careful
- Fill milk pitcher with 1/3 of its capacity with milk.
- Discharge any condensed water may have collected in the steam tube nozzle (17) by handle (12)
- Turn on handle (12) and insert the steam nozzle on top of the surface of the milk.
- Move up and down the surface of the milk with moderate steam power until a nice foam appears.
- At the requested formed foam Off steam handle (12).
- Clean steam tap tube (17) with a sponge or a wet cloth.

HOT-WATER DELIVERY

- Put the pot below the hot-water delivery (9)
- On hot water switch (10)
- Reached dose Off hot-water switch (10). If electronic dosing machine the delivery will stop automatically at dose reached

SOME SUGGESTIONS

How to make a good cup of coffee

- Do not use ready ground coffee, since it rapidly loses its aroma.
- If is absolutely necessary to use ready-ground coffee, purchase it in a small vacuum packs to be opened only as required and locate in a fresh side.
- The coffee machine must operate with the self dosing coffee grinder in order to grind each time the quantity of required coffee
- The grind discs of the coffee grinder must always be kept sharpened
- Do not keep large stocks of coffee beans, but only enough for a few hour's operation

The physical state of the ground coffee is fundamental for a good coffee

Slow delivery can be caused by:

- Excessive dose of ground coffee
- Too fine degree of grinding
- Filter partly clogged or dirty
- Too damp atmospheric humidity
- Excessive Pressure of ground coffee
- Presence of limestone

Fast delivery can be caused by

- Insufficient dose of ground coffee
- Too coarse degree of grinding
- Insufficient pressure of ground coffee
- Too used filter

MALFUNCTIONS AND REPAIRS

Trouble shooting for the user

Fault	Causes	Remedy
Cold unit, doesn't delivery coffee	Safety switch (4) off Main switch (8) off	Switch on Switch on
Machine hot, doesn't delivery coffee	Main cock (2) off Softener tap (26) off No water in the mains	Bring to working position Bring to working position Wait until it return
Pump don't stop	Main cock (29) off Softener tap (26) off	Bring to working position Bring to working position
Leak from filter holder rim	Bad hunger filter holder Filter holder gasket dirty Filter damage	Unlock and lock it again Clean with a brush To replace
Water leak under unit	Down bowl clogged	To clean
Ground coffee in the cup	Dirty filter holder Used filter	To clean To replace

TECHNICAL DEVICES

Mod. LUNA 2 GROUPS

Size	mm.	650x440hx500
Weight	Kg.	55
Boiler element	Watts	3000
Boiler capacity	Lt.	10
Operating boiler temp. (min./max)	C°	120/127
Operating temperature (min./max.)	C°	5/45
Box dimensions	cm.	80x70hx64

PROGRAMMING COFFEE DOSE'S

Water coffee programming (see Tavola GB 760)

- A – Press button T5 of **right** keyboard (11) until led lamp flashes
- B – Press button T1 and push same key again when wished portioning is reached
- C – Repeat the operations “A” and “B” on the remaining keys “T2” – “T3” – “T4”

Hot water (the) programming

- A - Press button T5 of programming keyboard (11) until led lamp flashes
- B – Press button (10) and when wished portioning is reached push same key again

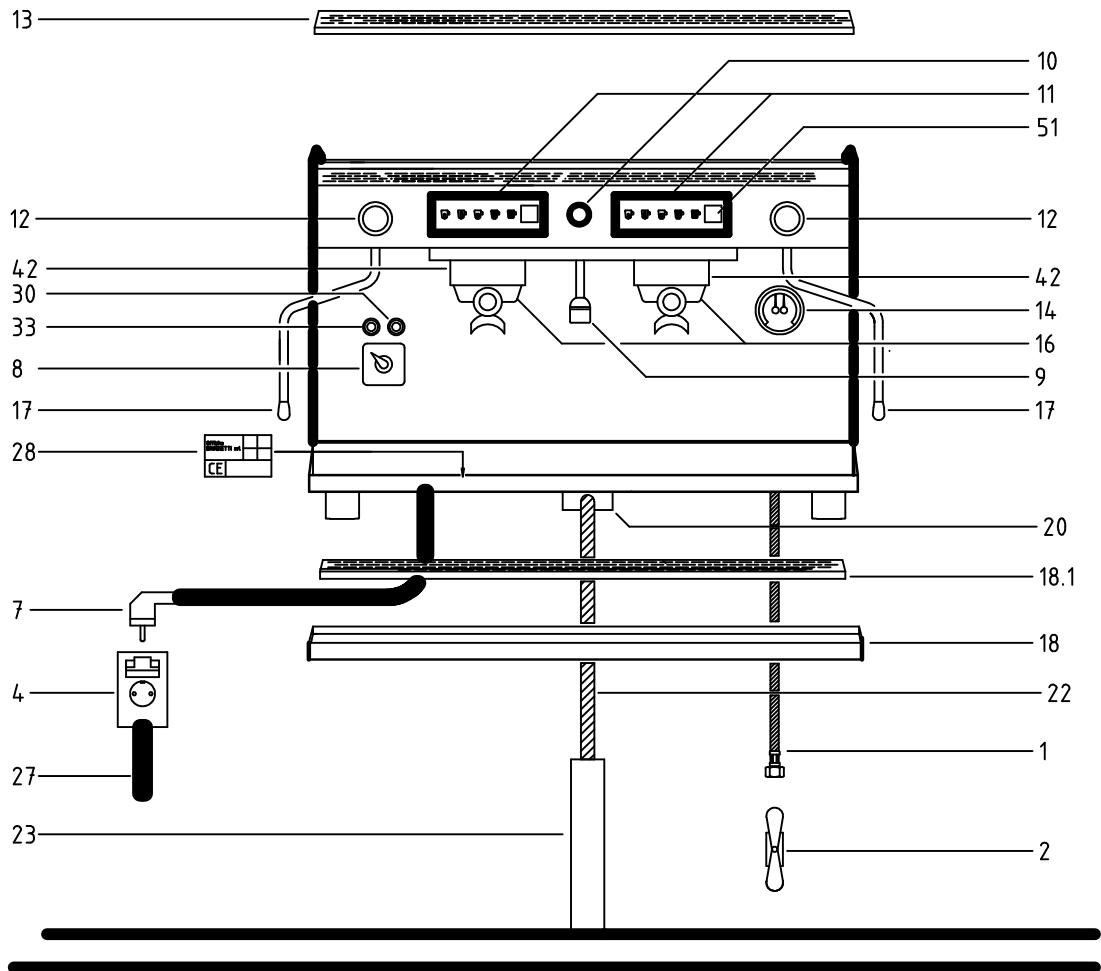

- 1 - Rete idrica
- 2 - Rubinetto rete idrica
- 4 - Presa di corrente
- 7 - Cavo alimentazione
- 8 - Interruttore di corrente
- 9 - Lancia acqua calda
- 10 - Tasto prelievo acqua calda
- 11 - Pulsantiera gruppo
- 12 - Rubinetto prelievo vapore
- 13 - Piano scaldatazze
- 14 - Manometro doppio
- 16 - Impugnatura portafiltro/portafiltro
- 17 - Lancia uscita vapore
- 18 - Bacinella
- 18.1 - Griglia bacinella
- 20 - Vaschetta di scarico
- 22 - Tubo di scarico
- 23 - Scarico generale
- 27 - Impianto elettrico
- 28 - Targa tecnica
- 30 - Indicatore arancione di riscaldamento
- 33 - Indicatore verde di accensione
- 42 - Gruppo erogatore caffè
- 51 - Shottimer

- 1 - Wassernetz
- 2 - Wasserhahn
- 4 - Sicherheitsschalter
- 7 - Anschlussspannung
- 8 - Hauptschalter
- 9 - Heisswasserrohr
- 10 - Wasserhahn
- 11 - Gruppentastatur
- 12 - Dampfahn
- 13 - Tassenvorwaermpalte
- 14 - Manometer (doppelt)
- 16 - Filterhalter
- 17 - Dampfrohr
- 18 - Tassenrost
- 18.1 - Grille tassenrost
- 20 - Ablaufwanne
- 22 - Auspuffrohr
- 23 - Allgemeiner Auspuff
- 27 - Stromnetz
- 28 - Technisches Verzeichnis
- 30 - Heizungskontrolleuchte (orange)
- 33 - Betriebskontrolleuchte (gruen)
- 42 - Gruppig
- 51 - Shottimer

- 1 - Hydric net
- 2 - Hydric net tap
- 4 - Power point
- 7 - Power supply cable
- 8 - Main switch
- 9 - Hot-water outlet
- 10 - Hot-water tap
- 11 - Coffee button
- 12 - Steam tap
- 13 - Cup-warmer bord
- 14 - Manometer (double)
- 16 - Filter holder
- 17 - Steam tube
- 18 - Cup-rest basin
- 18.1 - Grill basin
- 20 - Discharge tank
- 22 - Discharge tube
- 23 - General discharge
- 27 - Electrical network
- 28 - Technical plate
- 30 - Element lamp (orange)
- 33 - On/Off lamp (green)
- 42 - Group head
- 51 - Shottimer